

# Ultrashort Pulse InnoSlab Lasers PX-Series

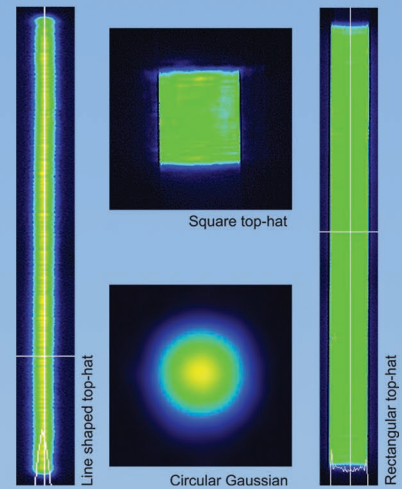
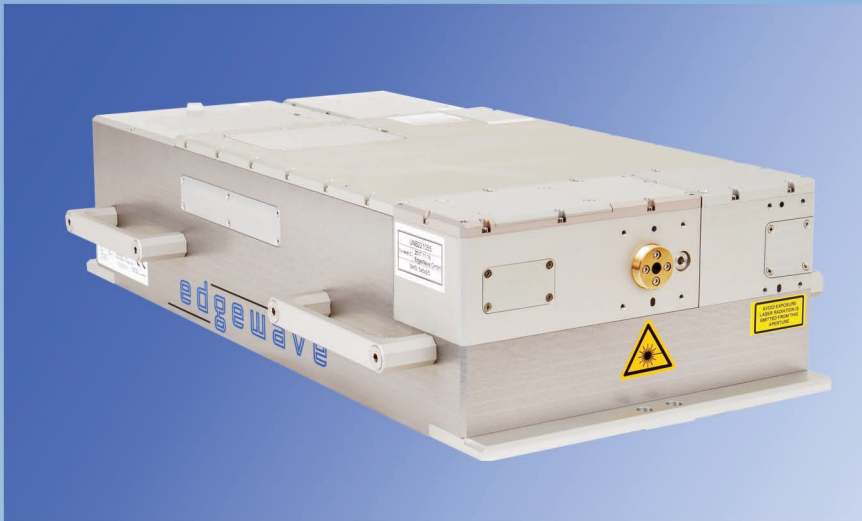

## Unique features

- ultrashort pulse length
- high pulse energy
- high peak power
- high repetition rate
- burst mode
- compact setup
- tailored beam profile

## Favourable applications

- milling, cutting and drilling of display-glass
- ablation and structuring of thin layer
- precision 3D engraving
- milling, drilling and cutting of CFP
- laser induced selective etching
- rapid prototyping

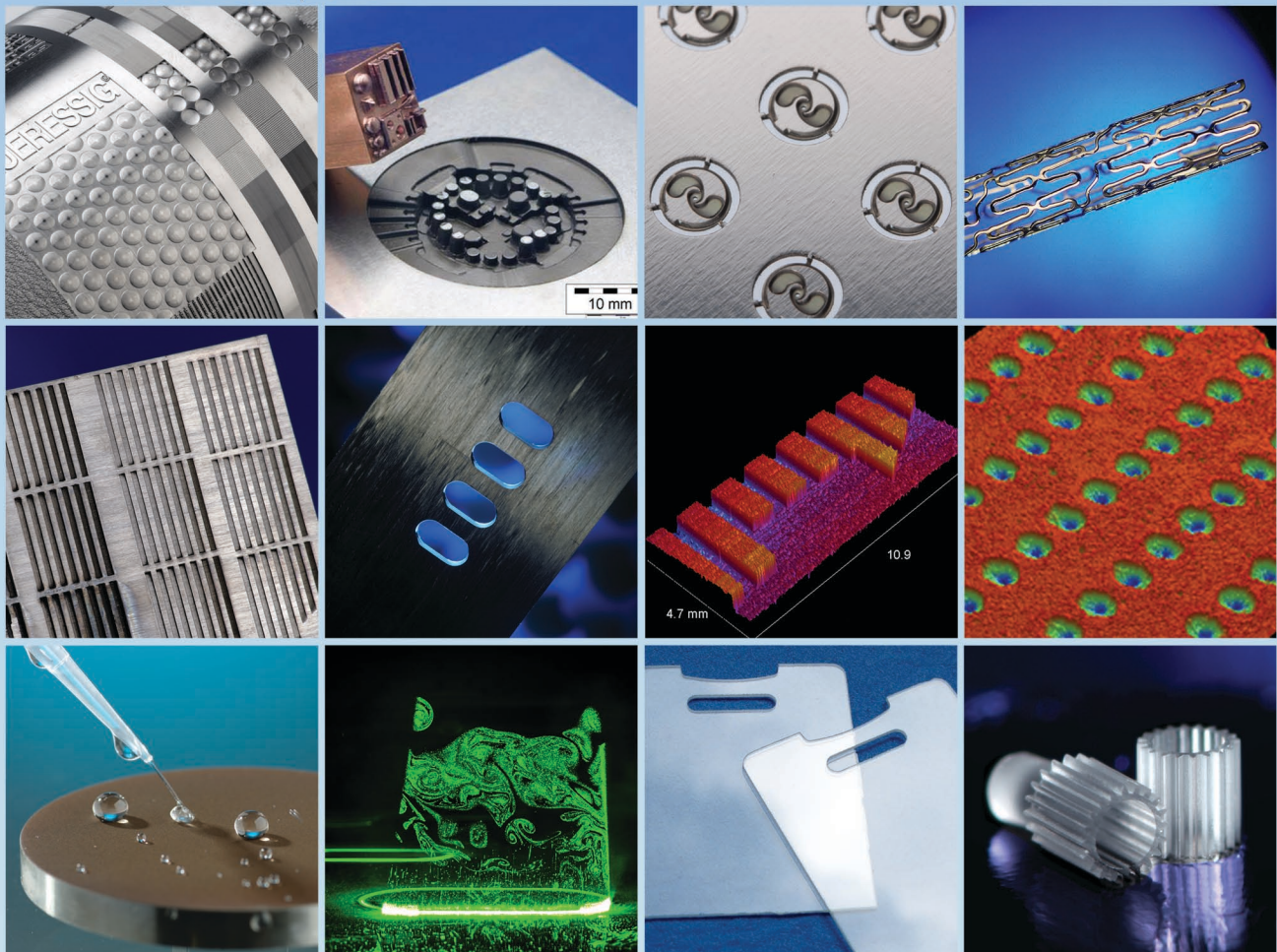

**edge wave**

Innovative Laser Solutions

EdgeWave GmbH, Carlo-Schmid-Straße 19, D-52146 Würselen  
Tel.: +49 2405 4186 0, Fax: +49 2405 4186 33  
email: [info@edge-wave.com](mailto:info@edge-wave.com) [www.edge-wave.com](http://www.edge-wave.com)

# Overview of PX-Series

Model	PXxxx-1	PXxxx-2	PXxxx-3	PXxxx-4
Wavelength [nm]	IR	Green	UV	DUV
Highest beam quality M <sup>2</sup>	1.1	1.1	1.5	2
Max. average power [W]	600	250	120	20
Max. repetition rate [MHz]	100	100	100	100
Max. pulse energy [μJ]	2000	1000	500	250
Pulse width [ps]	12	12	12	12
Energy stability [%] rms	1	2	2	3
Timing stability [ns]	20	20	20	20
Polarisation	> 100:1	> 100:1	> 100:1	> 100:1
Beam ellipticity (far field) [%]	< 10	< 10	< 10	< 10
Diameter at window [mm]	3	3	3	3
Full divergence angle [μrad]	500	250	226	226
Point stability [μrad]	< 100	< 100	< 100	< 100
Warm-up time, from cold start [min]	15	20	30	30
from standby [min]	8	15	30	30

## Utility & Ambient Requirements

Power supply	90V – 264V or 180 – 264V, 50/60Hz
Power	0.5kW – 5kW
Chiller	230, 208, 115, 100V, 50/60Hz
Power	0.8kW – 5kW
Operating ambient Temperature	15°C to 35°C
Relative Humidity, non-condensing	10% to 80%

## Dimensions & Weights

Laser head	650mm x 298mm x 150mm
Supply incl. Chiller	19" x (10HU – 15HU) x 700mm
Laser head	50kg
Supply incl. Chiller	62kg – 110kg

EdgeWave follows a policy of continuous product improvement. Specifications are subject to change without notice.

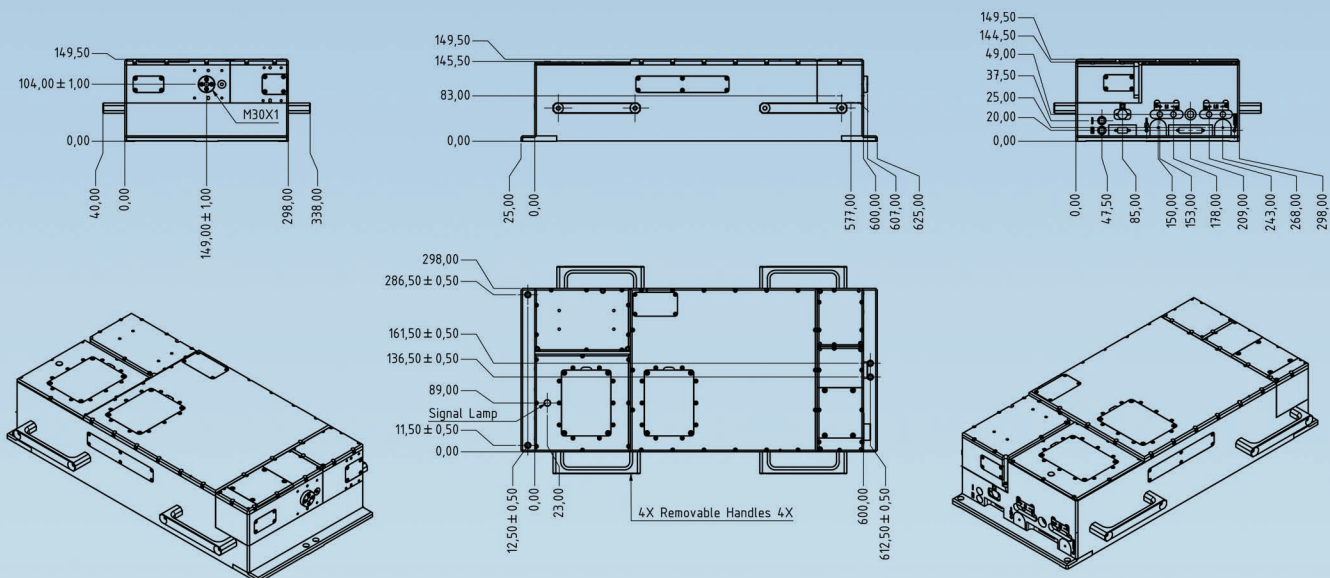

**edgewave**

Innovative Laser Solutions

EdgeWave GmbH, Carlo-Schmid-Straße 19, D-52146 Würselen  
 Tel.: +49 2405 4186 0, Fax: +49 2405 4186 33  
 email: [info@edge-wave.com](mailto:info@edge-wave.com) [www.edge-wave.com](http://www.edge-wave.com)